

SYJ SERIES

SIGHT GLASS

(Standard range: for fluids GROUP 2 according to Directive 2014/68/EU or GROUP A1 according to ANSI-ASHRAE 34-2016)
Sight glasses are installed after the filter drier in liquid line of refrigerating systems, in order to observe property changes of the refrigerant (liquid/vapor) and to indicate the moisture level by colors.



FEATURES

- HIGH PRECISION COLOR INDICATOR
- INDICATOR PASTED CLOSELY TO THE GLASS TO PREVENT SURFACE CONTAMINATION
- SOLID AND CORROSION RESISTANT BRASS MATERIAL
- GOOD READABILITY DUE TO HIGH CLEAR SIGHT GLASS OF WIDE ANGLE
- SEALING OF LOW CREEP PTFE TO ENSURE LEAKAGE FREE PERFORMANCE
- NEW ANNULAR HUMIDITY COLOR INDICATOR. FULL PORT PASSAGE WITH LOW PRESSURE DROP

GENERAL SPECIFICATION

- Applicable for all common HCFC, HFC, HFO refrigerants such as: R22, R134a, R404A, R410A, R507, R407C, R407A/F, R448A/R449A, R452A, R450A/R513A
- Ambient temperature min./max.: -50°C / +80°C
- Medium temperature TS min./max.: -50°C / +80°C
- Max. operating pressure PS: 4,6 MPa (46 bar)
- Installation position:
 - Liquid and suction line
 - Preferably in vertical lines, recommended position for horizontal lines is upwards without inclination in any direction
- Declaration according to PED (all products have been covered by Art.4.3 PED Directive 2014/68/EU)

SIGHT GLASS



Version with Solder Connections

General Characteristics										
Model Series	Model Name	Part Number (multi package) ¹⁾	Connection Type	Connecting ODF		Dimensions & Weight				
				Ød		L	H	H1	Weight	Drawing
				[inch]	[mm]	[mm]	[mm]	[mm]	[g]	
SYJ6	SYJ06H12	10285007102	ODF x ODF solder	-	6	101	24	14	100	A
SYJ6	SYJ06H11	10285007002		1/4	-	101	24	14	100	
SYJ10	SYJ10H11	10285007202		3/8	-	119	24	14	100	
SYJ10	SYJ10H12	10285007302		-	10	119	24	14	100	
SYJ12	SYJ12H11	10285006902		1/2	-	146	30	17	200	
SYJ12	SYJ12H12	10285007402		-	12	146	30	17	200	
SYJ16	SYJ16H11	10285007502		5/8	16	146	30	17	200	
SYJ19	SYJ19H11	10285007602		3/4	-	173	37	21	300	
SYJ22	SYJ22H11	10285007702		7/8	22	173	37	21	300	

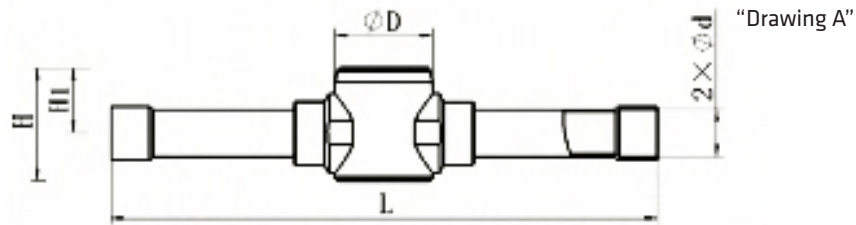

Version with male/male Flare Connections

General Characteristics										
Model Series	Model Name	Part Number (multi package) ¹⁾	Connection Type	SAE Flare	Dimensions & Weight					
				Ød	L	H	H1	Weight	Drawing	
				[inch]	[mm]	[mm]	[mm]	[g]		
SYJ6	SYJ06L11	10285007902	Flare M x M	1/4	67	24	14	110	B	
SYJ10	SYJ10L11	10285008102		3/8	82	24	14	240		
SYJ12	SYJ12L11	10285008302		1/2	88	30	17	250		
SYJ16	SYJ16L11	10285008502		5/8	104	32	17	320	C	
SYJ19	SYJ19L11	10285008702		3/4	110	32	15	340		

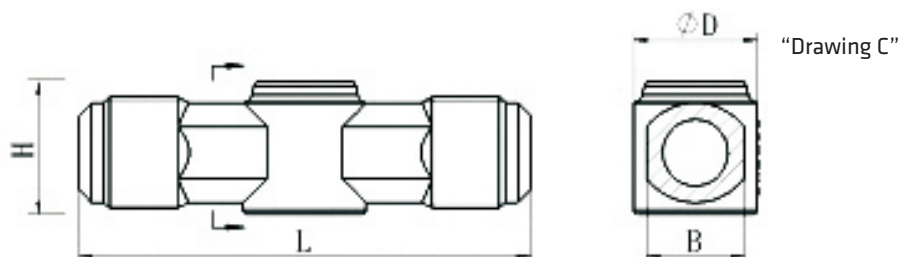
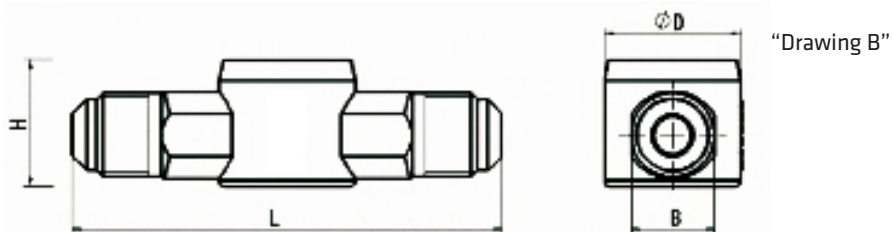

SIGHT GLASS



Version with male/female Flare connections

General Characteristics									
Model Series	Model Name	Part Number (multi package) ¹⁾	Connection Type	SAE Flare	Dimensions & Weight				
				Ød	H	φD	B	Weight	Drawing
				[inch]	[mm]	[mm]	[mm]	[g]	
SYJ6	SYJ06L41	10285008002	Flare F x M	1/4	30	32	22	200	D
SYJ10	SYJ10L41	10285008202		3/8	30	32	22	240	
SYJ12	SYJ12L41	10285008402		1/2	32	30	24	250	
SYJ16	SYJ16L41	10285008602		5/8	37	30	24	320	E
SYJ19	SYJ19L41	10285008802		3/4	37	30	24	330	

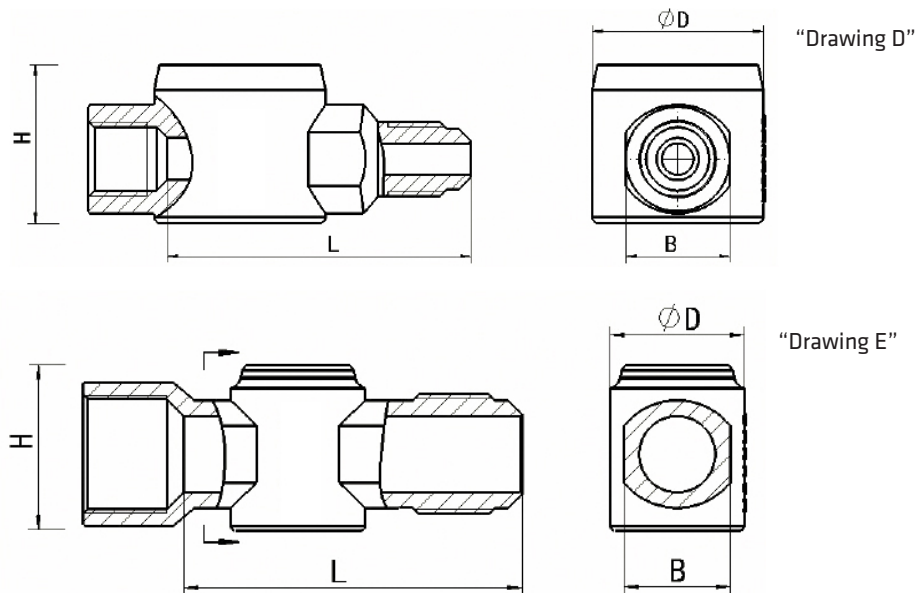

SIGHT GLASS



Moisture Indication Limits

Refrigerant	Moisture Content 25°C: PPM		
	Green/Dry	Middle Color	Yellow/Wet
R22	<100	100~200	>200
R134a	<90	90~180	>180
R404A	<40	40~100	>100
R410A	<90	90~300	>300
R507A	<15	15~90	>90
R407C	<120	120~280	>280
R407A	<180	180~340	>340
R448A	<220	220~440	>440
R449A	<180	180~380	>380
R452A ¹⁾	<50	50~120	>120
R450A ¹⁾	<45	45~260	>260
R513A	<180	180~280	>280

Note: 1) Calculated data based on refrigerant properties

Refrigerant	Moisture Content 40°C: PPM		
	Green/Dry	Middle Color	Yellow/Wet
R22	<140	140~350	>350
R134a	<120	120~330	>335
R404A	<80	80~160	>160
R410A	<200	200~580	>580
R507A	<80	80~170	>170
R407C	<100	100~260	>260
R407A	<200	200~560	>560
R448A	<220	220~480	>480
R449A	<200	200~450	>450
R452A ¹⁾	<90	90~170	>170
R450A ¹⁾	<110	110~420	>420
R513A	<200	200~380	>380

Note: 1) Calculated data based on refrigerant properties

SYJ SERIES

SIGHT GLASS

(GreenTech range: for fluids GROUP 1 according to Directive 2014/68/EU or GROUP A3/A2L according to ANSI-ASHRAE 34-2016)

Sight glasses are installed after the filter drier in liquid line of refrigerating systems, in order to observe property changes of the refrigerant (liquid/vapor) and to indicate the moisture level by colors.



FEATURES

- HIGH PRECISION COLOR INDICATOR
- INDICATOR PASTED CLOSELY TO THE GLASS TO PREVENT SURFACE CONTAMINATION
- SOLID AND CORROSION RESISTANT BRASS MATERIAL
- GOOD READABILITY DUE TO HIGH CLEAR SIGHT GLASS OF WIDE ANGLE
- SEALING OF LOW CREEP PTFE TO ENSURE LEAKAGE FREE PERFORMANCE
- NEW ANNULAR HUMIDITY COLOR INDICATOR. FULL PORT PASSAGE WITH LOW PRESSURE DROP

GENERAL SPECIFICATION

- Applicable for HC, HFC/HFO, HFO refrigerants such as: R290, R1234ze(E), R1234yf, R447A, R452B, R454B, R454C
- Ambient temperature min./max.: -50°C / +80°C
- Medium temperature TS min./max.: -50°C / +80°C
- Max. operating pressure PS: 4,6 MPa (46 bar)
- Installation position:
 - Liquid and suction line
 - Preferably in vertical lines, recommended position for horizontal lines is upwards without inclination in any direction
- Declaration according to PED (all products have been covered by Art.4.3 PED Directive 2014/68/EU)

SIGHT GLASS



GreenTech range: version with Solder Connections, MOP 46 bar

General Characteristics										
Model Series	Model Name	Part Number (multi package) ¹⁾	Connection Type	Connecting ODF		Dimensions & Weight				
				Ød		L	H	H1	Weight	Drawing
				[inch]	[mm]	[mm]	[mm]	[mm]	[g]	
SYJ6	SYJ06H12	10285007102	ODF x ODF solder	-	6	101	24	14	100	A
SYJ6	SYJ06H11	10285007002		1/4	-	101	24	14	100	
SYJ10	SYJ10H11	10285007202		3/8	-	119	24	14	100	
SYJ10	SYJ10H12	10285007302		-	10	119	24	14	100	
SYJ12	SYJ12H11	10285006902		1/2	-	146	30	17	200	
SYJ12	SYJ12H12	10285007402		-	12	146	30	17	200	
SYJ16	SYJ16H11	10285007502		5/8	16	146	30	17	200	
SYJ19	SYJ19H11	10285007602		3/4	-	173	37	21	300	
SYJ22	SYJ22H11	10285007702		7/8	22	173	37	21	300	

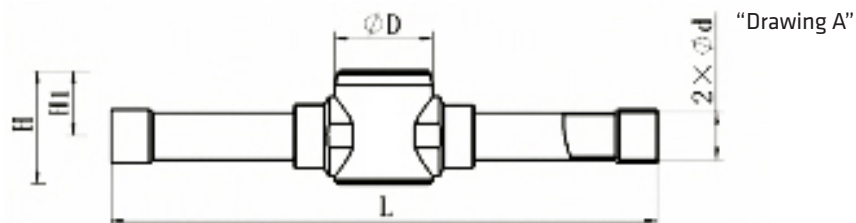

Refrigerant	Moisture Content 25°C: PPM		
	Green/Dry	Middle Color	Yellow/Wet
R290	<120	120~220	>220
R1234ze(E)	<120	120~200	>200
R1234yf	<100	100~180	>180
R452B ¹⁾	<95	95~290	>290
R454B ¹⁾	<115	115~290	>290
R454C ¹⁾	<75	75~160	>160

Refrigerant	Moisture Content 40°C: PPM		
	Green/Dry	Middle Color	Yellow/Wet
R290	<200	200~320	>320
R1234ze(E)	<140	140~260	>260
R1234yf	<180	180~300	>300
R452B ¹⁾	<210	210~330	>330
R454B ¹⁾	<150	150~340	>340
R454C ¹⁾	<85	85~2240	>240

Note: 1) Calculated data based on refrigerant properties