

## RFGB SERIES

# THERMOSTATIC EXPANSION VALVE

RFGB series thermostatic expansion valves are used to adjust mass flow of refrigerant into the evaporator while controlling the refrigerant's superheat at the outlet of the evaporator. They can be used for various refrigerants under all working conditions. Typical applications are refrigeration systems like commercial refrigerators and freezers, icemakers, dehumidifiers as well as air conditioners at various evaporation temperature. RFGB 06 series has been designed and optimized for application with propane (R290).

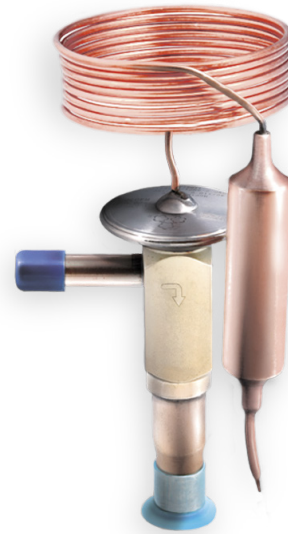

## FEATURES

- COMPACT DESIGN WITH BUILD-IN ORIFICE
- WARM THERMO HEAD CONSTRUCTION
- ALL CONNECTIONS PIPES ARE COMPLETELY IN COPPER
- VALVES WITH MOP FUNCTION CAN BE PROVIDED TO ASSURE RELIABLE COMPRESSOR OPERATION
- APPLICABLE IN A WIDE EVAPORATION TEMPERATURE RANGE
- RELIABLE AND CONSISTENT PERFORMANCE OF SUPERHEAT CONTROL

## GENERAL SPECIFICATION

- Special series designed for application with R290
- Ambient temperature min./max.: -35/+55°C
- Medium temperature TS min./max.: -40°C / +70°C
- Factory setting for static super heat: 3.5 K (4.0K for few models)
- Max. operating pressure PS: 3,5 MPa (35 bar)
- Installation position:
  - Preferably valve head upwards
  - Flow direction from inlet A to outlet B
- Certifications: UL/CSA and PED declaration

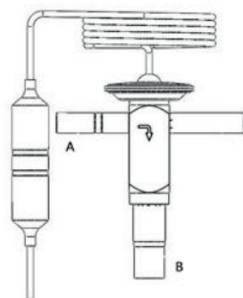

Angle version

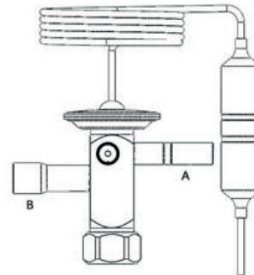

Straight version

# THERMOSTATIC EXPANSION VALVE



## TECHNICAL PARAMETERS

- RFGB valve available in straight shape with adjustable superheat on site
- RFGB valve available in angle shape with fixed factory superheat settings
- Both versions are available with the following solder connections
  - Metric: Inlet 6mm ODF/ Outlet 10mm ODF or Inlet 10mm ODF/ Outlet 12mm ODF
  - Imperial: Inlet 1/4" ODF/ Outlet 3/8" ODF or Inlet 3/8" ODF/ Outlet 1/2" ODF
- Equalization port available as option:
  - Metric: 6mm ODF (available for models with metric solder connections)
  - Imperial: 1/4" ODF (available for models with imperial solder connections)
- Capillary tube length 800mm

## MODEL DESIGNATION LEGEND

Position Number	Model Designation Legend	
1	<b>Product Code</b>	<b>Product Series</b>
	RFGB	Thermostatic expansion valve with build-in orifice
2	<b>Refrigerant</b>	<b>Description</b>
	06	R290
3	<b>Pressure Equalization</b>	<b>Description</b>
	E	External pressure equalization
	(Omitted)	Internal pressure equalization
4	<b>Valve Size</b>	<b>Internal Orifice Size</b>
	X.XX	Nominal capacity (expressed in USRT)
5	<b>Valve Shape</b>	<b>Description</b>
	Internal Code	Description
	XXX	Internal consequential code

# THERMOSTATIC EXPANSION VALVE

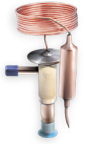

## MODEL DESIGNATION EXAMPLE

Position Number					According to Model Designation Legend
1	2	3	4	5	
<b>RFGB</b>	06	E	1.0	xxx	Thermostatic expansion valve with build-in orifice
RFGB	<b>06</b>	E	1.0	xxx	Refrigerant: R290
RFGB	06	<b>E</b>	1.0	xxx	With connection for external pressure equalization
RFGB	06	E	<b>1.0</b>	xxx	Capacity: Nominal value 1.0 USRT (3.5kW)
RFGB	06	E	1.0	xxx	Internal consequential code



Code	Description
GB06E-1.0-518	Model
-40/+10°C	Evaporator temperature in °C
-40/+50°F	Evaporator temperature in °F
R290	Refrigerant
MWP 3.5Mpa	Max. Working Pressure in MPa
MWP 505psig	Max. Working Pressure in Psig

## TECHNICAL DATA

Nominal Cooling Capacities <sup>1)2)</sup>					
Refrigerant	Size	Valve Nomenclature	Capacity		PS
			[ USRT ]	[ kW ]	[ MPa ]
R290	0	RFGB06(E)-0.17-xxx	0,17	0,60	3,5
	1	RFGB06(E)-0.35-xxx	0,35	1,20	
	2	RFGB06(E)-0.7-xxx	0,70	2,50	
	3	RFGB06(E)-1.0-xxx	1,00	3,50	
	4	RFGB06(E)-1.5-xxx	1,50	5,30	
	5	RFGB06(E)-2.0-xxx	2,00	7,00	

**Note:**

- 1) Nominal capacity valid for: - Version in straight and angle shape  
- Versions with metrical and imperial connections
- 2) Nominal working conditions: Condensing temperature: 38°C; evaporating temperature +4,4°C;  
Liquid temperature 37°C

# THERMOSTATIC EXPANSION VALVE

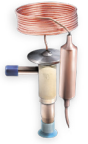

## MODEL LIST – TABLE 1

Temperature Range N: from -40°C to +10°C, without MOP  
 Models with Straight layout and adjustable static superheat setting  
 Models with Imperial Connections

Model Name	Product Number U11 code Multi-Pack	Valve Size	Capacity		Bleed	Connections (Solder ODF)	
			[USRT]	[kW]		IN/OUT	Equalization
					[inch]	[inch]	
RFGB06-0.17-450	10205126802	0	0,17	0,60	15%	1/4"; 3/8"	-
RFGB06E-0.17-453	10205096402	0	0,17	0,60	15%	1/4"; 3/8"	1/4
RFGB06-0.35-525	10205115102	1	0,35	1,20	15%	1/4"; 3/8"	-
RFGB06-0.35-526	10205115202	1	0,35	1,20	0%	1/4"; 3/8"	-
RFGB06-0.35-527	10205115302	1	0,35	1,20	0%	1/4"; 1/2"	-
RFGB06E-0.35-528	10205115402	1	0,35	1,20	15%	1/4"; 3/8"	1/4
RFGB06E-0.35-536	10205122802	1	0,35	1,20	0%	1/4"; 3/8"	1/4
RFGB06E-0.7-537	10205122902	2	0,70	2,50	0%	1/4"; 3/8"	1/4
RFGB06E-1.0-518	10205114802	3	1,00	3,50	0%	3/8"; 1/2"	1/4
RFGB06E-1.5-519	10205114902	4	1,50	5,30	0%	3/8"; 1/2"	1/4
RFGB06E-2.0-520	10205115002	5	2,00	7,00	0%	3/8"; 1/2"	1/4

## MODEL LIST – TABLE 2

Temperature Range N: from -40°C to +10°C, without MOP  
 Models with Straight layout and adjustable static superheat setting  
 Models with Metric Connections

Model Name	Product Number U11 code Multi-Pack	Valve Size	Capacity		Bleed	Connections (Solder ODF)	
			[USRT]	[kW]		IN/OUT	Equalization
					[inch]	[inch]	
RFGB06-0.17-521	10205115502	0	0,17	0,60	15%	6; 10	-
RFGB06E-0.17-534	10205123102	0	0,17	0,60	15%	6; 10	-
RFGB06-0.35-522	10205115602	1	0,35	1,20	15%	6; 10	-
RFGB06-0.35-538	10205123202	1	0,35	1,20	0%	6; 10	-
RFGB06E-0.35-523	10205115702	1	0,35	1,20	15%	6; 12	6
RFGB06E-0.35-524	10205115802	1	0,35	1,20	0%	6; 12	6
RFGB06E-0.7-483	10205092602	2	0,70	2,50	0%	6; 10	6
RFGB06E-0.7-457	10205077202	2	0,70	2,50	0%	10; 12	6
RFGB06E-1.0-470*	10205087402	3	1,00	3,50	0%	10; 12	6
RFGB06E-1.5-465*	10205087302	4	1,50	5,30	0%	10; 12	6
RFGB06E-2.0-466*	10205126902	5	2,00	7,00	0%	10; 12	6

- Note:** 1) Different evaporation temperature range on request  
 2) Extent of delivery: valve body and bulb strap  
 3) MOP function on request  
 4) \* Models with Static SH: 4K

# THERMOSTATIC EXPANSION VALVE

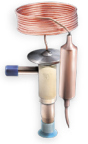

## DIMENSIONS - STRAIGHT SHAPE VERSION

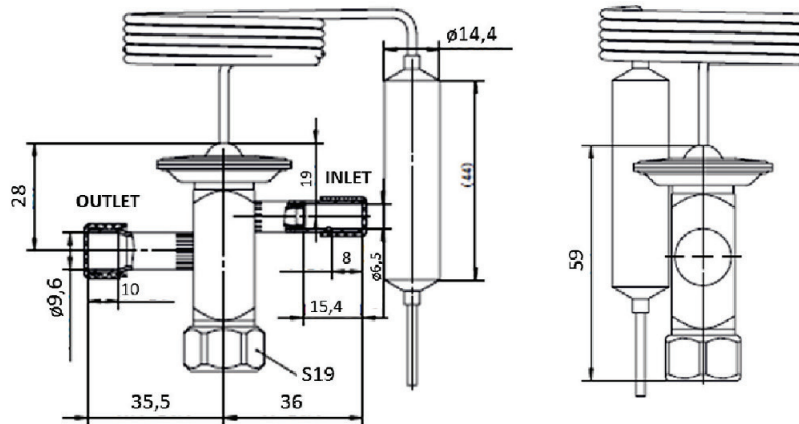

*Straight Shape with Internal Pressure Equalization*

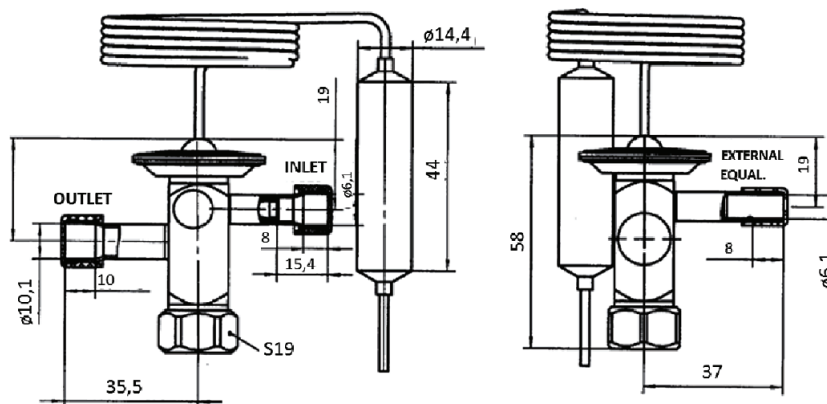

*Straight Shape with External Pressure Equalization*

## THERMOSTATIC EXPANSION VALVE



### MODEL LIST – TABLE 3

Temperature Range N: from -40°C to +10°C, without MOP  
 Models with Angle layout and fixed static super-heat setting  
 Models with Imperial Connections

Model Name	Product Number U11 code Multi-Pack	Valve Size	Capacity		Bleed	Connections (Solder ODF)	
			[USRT]	[kW]		IN/OUT	Equalization
					[inch]	[inch]	
RFGB06-0.17-719	10205115902	0	0,17	0,60	15%	1/4"; 3/8"	-
RFGB06-0.17-735	10205123002	0	0,17	0,60	0%	1/4"; 3/8"	-
RFGB06-0.35-652	10205127002	1	0,35	1,20	15%	1/4"; 3/8"	-
RFGB06-0.35-736	10205053302	1	0,35	1,20	0%	1/4"; 3/8"	-
RFGB06E-0.35-720	10205116002	1	0,35	1,20	15%	1/4"; 3/8"	1/4
RFGB06E-0.35-721	10205116102	1	0,35	1,20	0%	1/4"; 3/8"	1/4
RFGB06E-0.7-722	10205116202	2	0,70	2,50	0%	1/4"; 3/8"	1/4
RFGB06E-1.0-723	10205116302	3	1,00	3,50	0%	3/8"; 1/2"	1/4
RFGB06E-1.5-724	10205116402	4	1,50	5,30	0%	3/8"; 1/2"	1/4
RFGB06E-2.0-725	10205116502	5	2,00	7,00	0%	3/8"; 1/2"	1/4

### MODEL LIST – TABLE 4

Temperature Range N: from -40°C to +10°C, without MOP  
 Models with Angle layout and fixed static super-heat setting  
 Models with Metric Connections

Model Name	Product Number U11 code Multi-Pack	Valve Size	Capacity		Bleed	Connections (Solder ODF)	
			[USRT]	[kW]		IN/OUT	Equalization
					[inch]	[inch]	
RFGB06-0.17-726	10205116602	0	0,17	0,60	15%	6; 10	-
RFGB06-0.17-737	10205123402	0	0,17	0,60	0%	6; 10	-
RFGB06-0.35-727	10205116702	1	0,35	1,20	15%	6; 10	-
RFGB06-0.35-738	10205123502	1	0,35	1,20	0%	6; 10	-
RFGB06E-0.35-728	10205116802	1	0,35	1,20	15%	6; 10	6
RFGB06E-0.35-729	10205116902	1	0,35	1,20	0%	6; 10	6
RFGB06E-0.7-730	10205117002	2	0,70	2,50	0%	10; 12	6
RFGB06E-1.0-731	10205117102	3	1,00	3,50	0%	10; 12	6
RFGB06E-1.5-732	10205117202	4	1,50	5,30	0%	10; 12	6
RFGB06E-2.0-733	10205117302	5	2,00	7,00	0%	10; 12	6

**Note:** 1) Different evaporation temperature range on request  
 2) Extent of delivery: valve body and bulb strap  
 3) MOP function on request

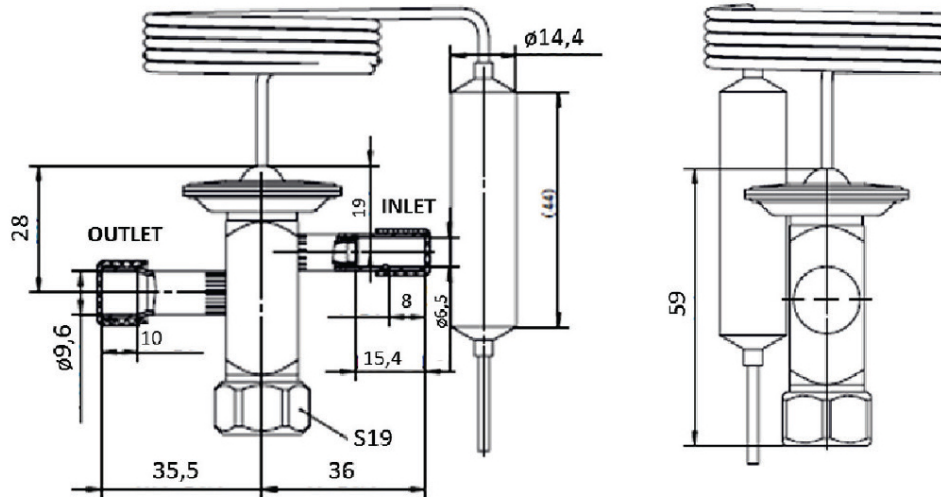

*Angle Shape with Internal Pressure Equalization*

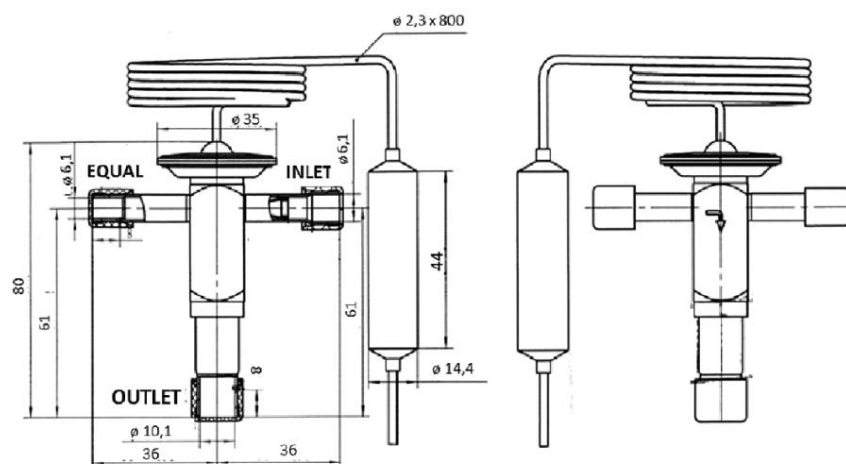

*Angle Shape with External Pressure Equalization*