

PS01/50/15 SERIES

PRESSURE CONTROLS

Pressure controls can be used in refrigeration and air conditioning systems to protect the systems from extremely low suction pressure or extremely high discharge pressure. The pressure controls are also used to start or stop the refrigeration compressors and air-cooled condenser fans, to regulate other components in the systems which require pressure control function.



FEATURES

- HIGH LEVEL OF ACCURACY AND STABLE REPEATABILITY
- LONG LIFE TIME WITH BOTH EXCELLENT ELECTRIC AND MECHANICAL RELIABILITY
- SPDT SWITCH TO ENSURE GOOD CONTACT AND DISCONNECT CONVERSION WITH FAST REACTIONS
- VARIOUS PRESSURE RANGES ARE AVAILABLE
- STANDARD PLATE FOR INSTALLATION
- BELLOW ELEMENTS ARE MADE OF TIN BRONZE AND PRESSURE CONNECTIONS ARE MADE OF BRASS

GENERAL SPECIFICATION

- Applicable for all common HCFC, non-flammable HFC and HFO refrigerants such as: R134a, R404A/R507, R407C, R22, R407A/F, R448A/449A, R452A, R513A, R450A,.
- Medium temperature TS min./max. -40°C /+120°C
- Ambient temperature min./max. -30°C /+65°C
- Relative humidity: 0 - 95% RH
- Max. working pressure (PS): HP: 3.5MPa; LP: 1.65MPa
- Enclosure: IP44
- Certification: CE, PED IV and UL Listed
- Contact load

Contact load	AC1	AC3	AC15	DC
Rated Voltage (V)	400	400	400	24
Rated Current (A)	16	16	10	16

PRESSURE CONTROLS



MODEL DESIGNATION LEGEND

Position Number	Model Designation Legend	
1	Type of pressure control	Description
	PS	Pressure control
2	Pressure regulating range	Description
	01	LP:-0.5~7 bar(g)
	02	TBD
	03	TBD
	50	HP:6~32 bar(g)
	60	HP:642 bar(g)
	70	TBD
	80	TBD
	15	Dual (LP/HP): LP:-0.5 ~ 7 bar(g)/ HP:6~32 bar(g)
	16	Dual (LP/HP): LP:-0.5 ~7 bar(g)/ HP:6~42 bar(g)
	55	Dual (HP/HP): HP:6~32 bar(g)/ HP:6~32 bar(g)
3	Type of reset	Description
	A	Automatic reset
	M	Manual reset
	C	Convertible reset
	AA	Auto LP/ Auto HP
	AC	Auto LP/Convertible HP
	AM/MA/MM/MC/CA/CM/CC
4	Pressure connection type	Description
	L	Flare
	H	Solder
	M	Capillary tube
5	Product design (type)	Description
	S	Standard
	C	Customized
6	inch or mm pressure connection	Description
	01 (03/05/07/09/11/13.....)	Inch or unified Inch & Metric (will be certified as Cat. IV)
	02 (04/06/08/10/12/14.....)	Metric only (will be certified as Cat. IV)
	51 (53/55/57/59/61/63....)	Inch or unified Inch & Metric
	52 (54/56/58/60/62/64....)	Metric only

PRESSURE CONTROLS



MODEL DESIGNATION EXAMPLE

Position Number							Model designation example (according above legend)
1	2	3	4	-	5	6	
PS	15	AA	L	-	S	01	Pressure control
PS	15	AA	L	-	S	01	Dual Pressure Range LP:-0.5~7 bar(g)/ HP:6~32 bar(g)
PS	15	AA	L	-	S	01	Auto reset HP, Auto reset LP
PS	15	AA	L	-	S	01	Flare connection type
PS	15	AA	L	-	S	01	Standard
PS	15	AA	L	-	S	01	Inch (or unified Inch & Metric) pressure connection Double bellows - fail safe in case of High pressure

SELECTION AND ORDERING

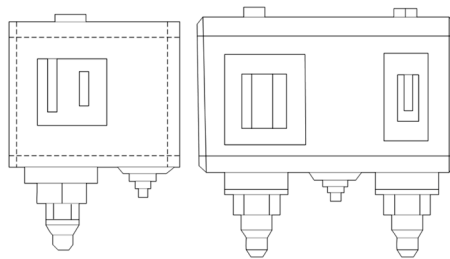

PS01, PS50, PS15, Flare Connection										
Pressure	Type	Low Pressure (LP)		High Pressure (HP)		Reset		PED 2014 68/EU EN 12263 Certified ¹⁾	Ordering Code	
		Range	Differential Pressure ΔP	Range	Differential Pressure ΔP	Low Pressure	High Pressure		Flare Connection 7/16-20UNF (1/4in. & 6mm)	
		[bar]	[bar]	[bar]	[bar]				Model	U11 Code
Low	PS01 ²⁾	-0.5~7	0.5~5	—	—	Auto	—	Compliant	PS01AL-S01	10660003102
Low	PS01	-0.5~7	1	—	—	Manual	—	Compliant	PS01ML-S01	10660003202
High	PS50	—	—	6~32	3~15	—	Auto	NO	PS50AL-S51	10660002702
High	PS50	—	—	6~32	4	—	Manual	NO	PS50ML-S51	10660003302
High	PS50	—	—	6~32	3~15	—	Auto	Compliant	PS50AL-S01	10660003002
High	PS50	—	—	6~32	4	—	Manual	Compliant	PS50ML-S01	10660003402
Dual	PS15	-0.5~7	0.5~5	6~32	4	Auto	Auto	NO	PS15AAL-S51	10660002802
Dual	PS15	-0.5~7	0.5~5	6~32	4	Auto	Manual	NO	PS15AML-S51	10660003502
Dual	PS15	-0.5~7	0.5~5	6~32	4	Auto	Auto	Compliant	PS15AAL-S01	10660002902
Dual	PS15	-0.5~7	0.5~5	6~32	4	Auto	Manual	Compliant	PS15AML-S01	10660003602

PRESSURE CONTROLS



SELECTION AND ORDERING

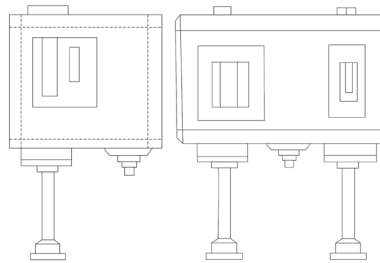

PS01, PS50, PS15, Solder ODF Connection												
Pressure	Type	Low Pressure (LP)		High Pressure (HP)		Reset		PED 2014 68/EU EN 12263 Certified ¹⁾	Ordering Code			
		Range	Differential Pressure ΔP	Range	Differential Pressure ΔP				Solder ODF 1/4 in.		Solder ODF 6mm	
		[bar]	[bar]	[bar]	[bar]	Low Pressure	High Pressure		Model	U11 Code	Model	U11 Code
Low	PS01	-0.5~7	0.5~5	—	—	Auto	—	Compliant	PS01AH-S01	10660003702	PS01AH-S02	10660005302
Low	PS01	-0.5~7	1	—	—	Manual	—	Compliant	PS01MH-S01	10660003802	PS01MH-S02	10660005202
High	PS50	—	—	6~32	3~15	—	Auto	NO	PS50AH-S51	10660003902	PS50AH-S52	10660005102
High	PS50	—	—	6~32	4	—	Manual	NO	PS50MH-S51	10660004002	PS50MH-S52	10660005002
High	PS50	—	—	6~32	3~15	—	Auto	Compliant	PS50AH-S01	10660004102	PS50AH-S02	10660004902
High	PS50	—	—	6~32	4	—	Manual	Compliant	PS50MH-S01	10660004602	PS50MH-S02	10660004802
Dual	PS15	-0.5~7	0.5~5	6~32	4	Auto	Auto	NO	PS15AAH-S51	10660004502	PS15AAH-S52	10660006702
Dual	PS15	-0.5~7	0.5~5	6~32	4	Auto	Manual	NO	PS15AMH-S51	10660004402	PS15AMH-S52	10660004702
Dual	PS15	-0.5~7	0.5~5	6~32	4	Auto	Auto	Compliant	PS15AAH-S01	10660004302	PS15AAH-S02	10660005402
Dual	PS15	-0.5~7	0.5~5	6~32	4	Auto	Manual	Compliant	PS15AMH-S01	10660004202	PS15AMH-S02	10660005602

PRESSURE CONTROLS



SELECTION AND ORDERING

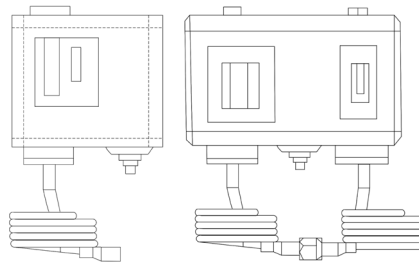

PS01, PS50, PS15, Capillary Connection										
Pressure	Type	Low Pressure (LP)		High Pressure (HP)		Reset		PED 2014 68/EU EN 12263 Compliant ¹⁾	Connection	
		Range	Differential Pressure ΔP	Range	Differential Pressure ΔP	Low Pressure	High Pressure		Capillary with 7/16-20UNF Flare Nut (1/4in. & 6mm)	
		[bar]	[bar]	[bar]	[bar]				Model	U11 Code
Low	PS01	-0.5~7	0.5~5	—	—	Auto	—	Compliant	PS01AM-S01	10660006102
Low	PS01	-0.5~7	1	—	—	Manual	—	Compliant	PS01MM-S01	10660006002
High	PS50	—	—	6~32	3~15	—	Auto	Not	PS50AM-S51	10660005902
High	PS50	—	—	6~32	4	—	Manual	Not	PS50MM-S51	10660005802
High	PS50	—	—	6~32	3~15	—	Auto	Compliant	PS50AM-S01	10660005702
High	PS50	—	—	6~32	4	—	Manual	Compliant	PS50MM-S01	10660006602
Dual	PS15	-0.5~7	0.5~5	6~32	4	Auto	Auto	Not	PS15AAM-S51	10660006502
Dual	PS15	-0.5~7	0.5~5	6~32	4	Auto	Manual	Not	PS15AMM-S51	10660006402
Dual	PS15	-0.5~7	0.5~5	6~32	4	Auto	Auto	Compliant	PS15AAM-S01	10660006302
Dual	PS15	-0.5~7	0.5~5	6~32	4	Auto	Manual	Compliant	PS15AMM-S01	10660006202

Notes: 1) PS50 and PS15 which are certified by TÜV, Rheinland acc. to PED 2014 68/EU, EN12263 are designed with double bellows at high pressure and they provide fail-safe function (models without PED 2014 68/EU Certificate can be used as pressure regulation devices, usage them as pressure safety devices must be verified as per local legislation in the country of use). Regarding availability of PED 2014 68/EU (Category IV)

The double bellows system prevents loss of charge in the event of the inner bellow rupture. A rupture in the inner bellow will cause the control cut-out pressure to fall about 3 times less the set value and the compressor will stop. A rupture in the outer bellows will cause the control cut-out pressure to fall to about 3 bar under the set value and providing the so-called 'fail-safe' function.

2) The PS01 are certified by TÜV, Rheinland acc. to PED 2014 68/EU, EN12263 but due to the fact that they will not be used as high pressure protection function, PED IV is not required and they are designed with only single bellow.

PRESSURE CONTROLS



DIMENSIONAL DRAWINGS

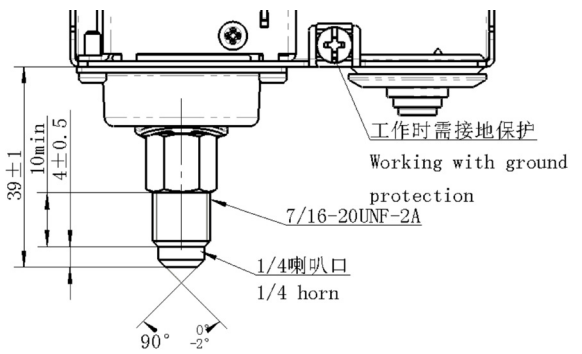
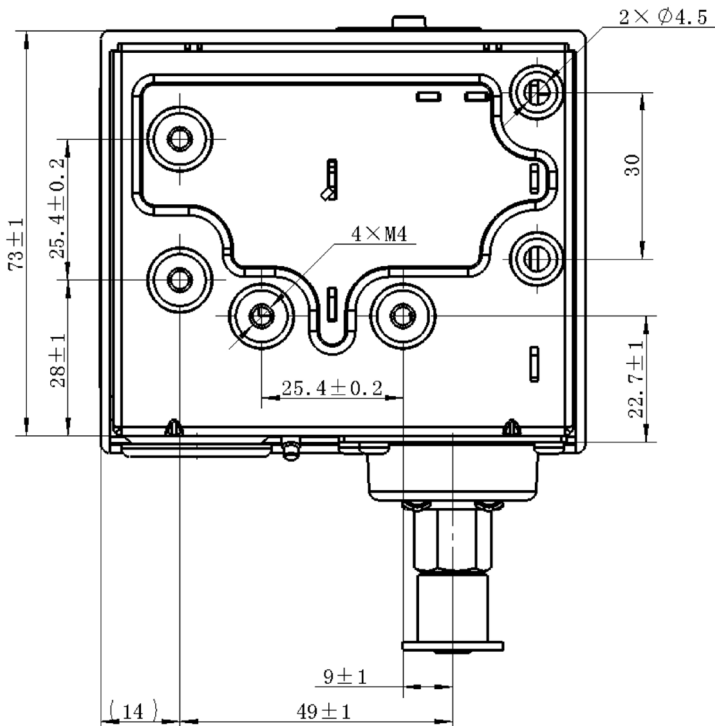
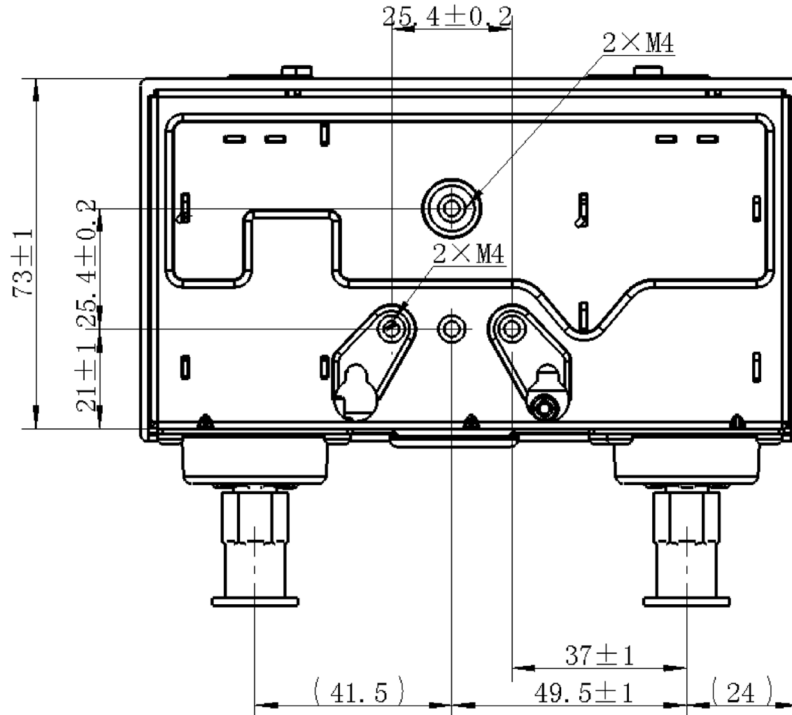

PRESSURE CONTROLS



DIMENSIONAL DRAWINGS

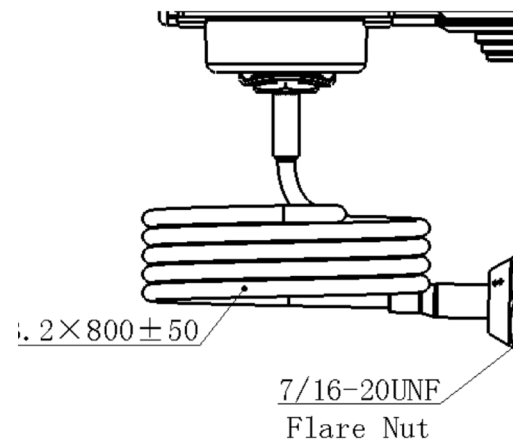
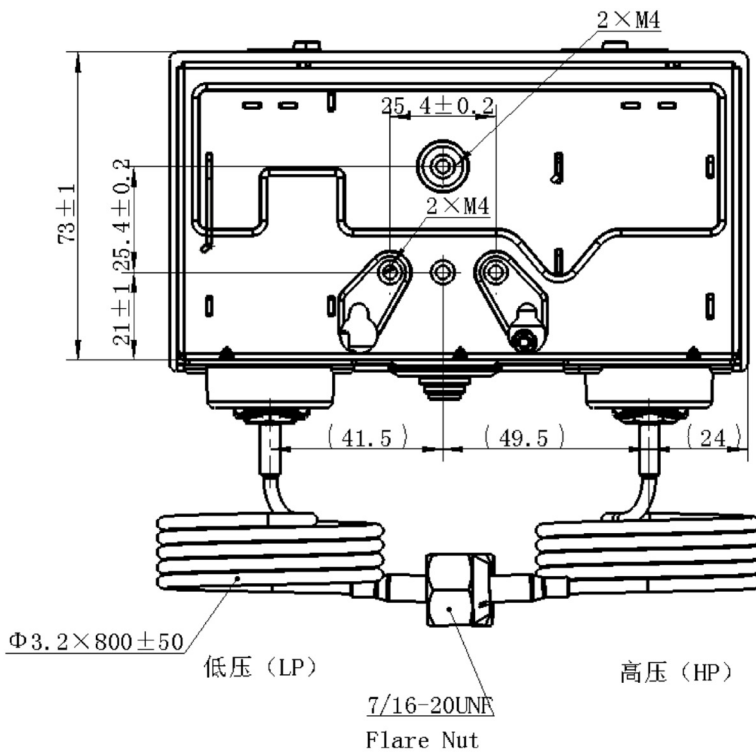
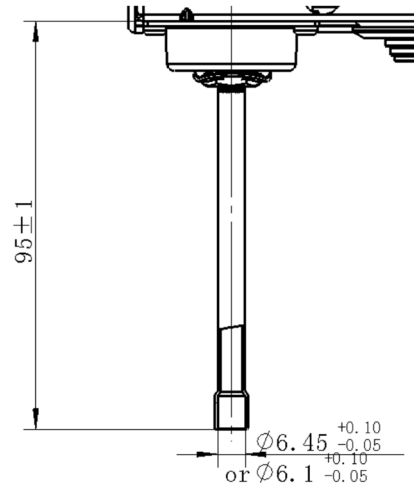
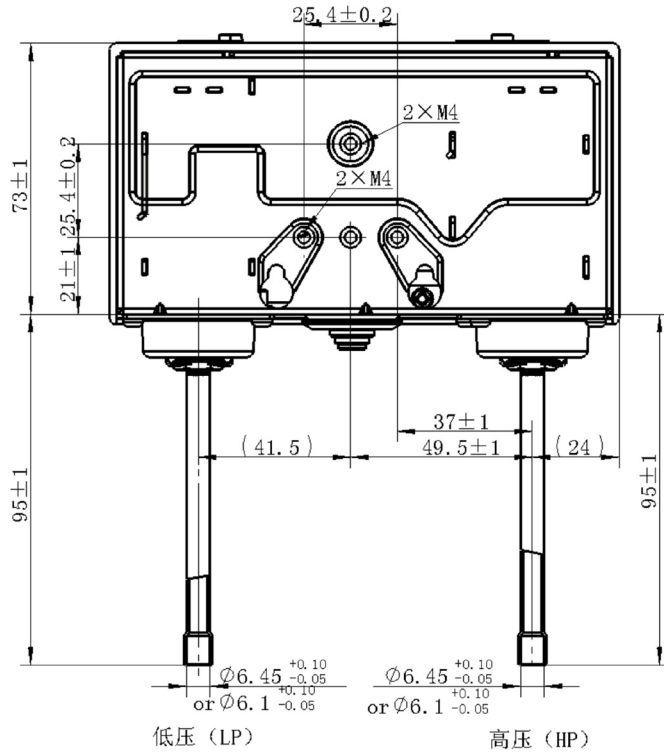

PRESSURE CONTROLS



MOUNTING PLATE

Model: PS50-50001

U11 code: 20660018502

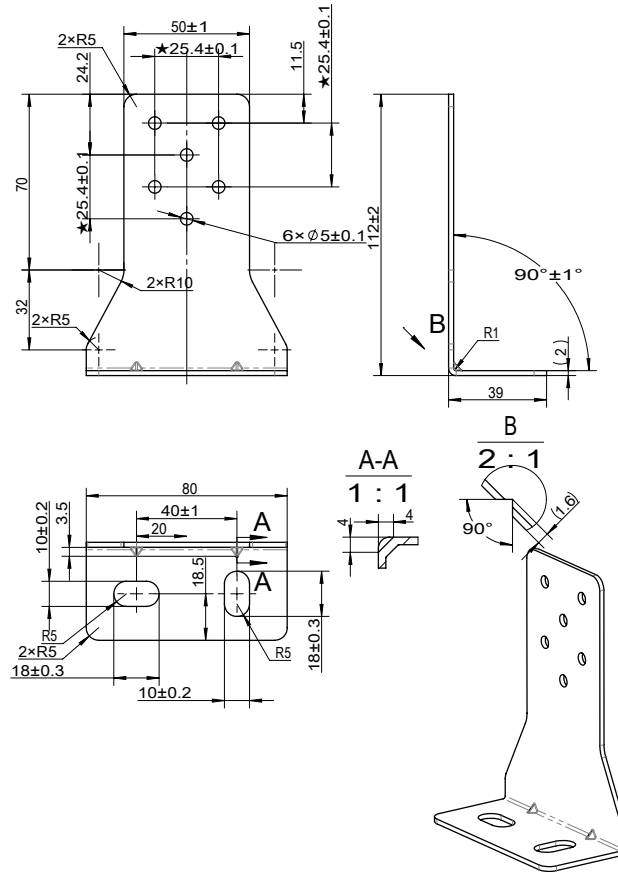

CONTACT SYSTEM

Single PS01

Single PS50

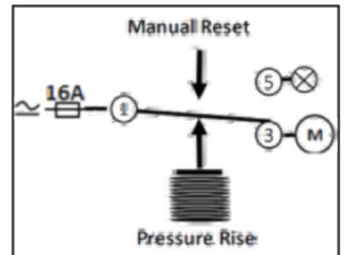
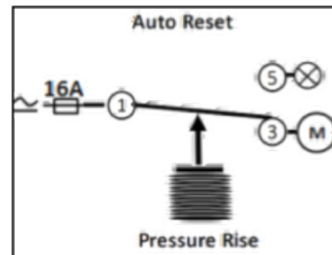
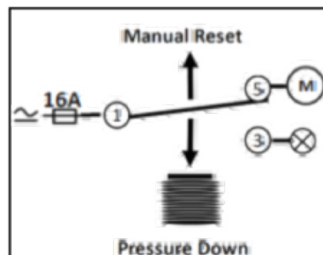
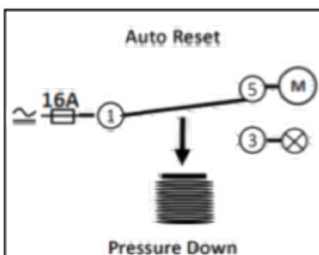

Dual PS15

