

HTG SERIES

FILTER DRIERS WITH REPLACEABLE CORE

The filter driers with replaceable core (HTG series) are used in liquid line and suction line of refrigerating, freezing and air conditioning system. The filter housing allows to choose different kinds of cores. It's sealed by bottom cover for an easy removal and replacement of core from the bottom. The core holder requires minimum free space to remove the core for replacement.



FEATURES

- HIGH EFFICIENT IN MOISTURE ABSORPTION, FILTERING IMPURITY, ACID, PAINT REMAINS AND MUD REMOVAL
- DIFFERENT TYPES OF FILTER CORES
- DURABLE AND SOLID FILTER CORES
- FILTERING FINENESS: 20 μ m
- CORROSION RESISTANT PAINTING CAN SURVIVE SALT SPRAY TEST OF 500 HOURS
- CONNECTION TYPE: SOLDER

FEATURES OF FILTER ELEMENT

- **SH48-A80 FILTER ELEMENT:**
80% 3A DESICCANT AND 20% ACTIVATED ALUMINA,
It provides a good desiccation ability and an acid absorption capability in a wide temperature range. The core resistance is guaranteed with high level of vibration thanks to an anti-shock design. Suggested installation position on liquid line
- **SH48-A00 FILTER ELEMENT:**
100% 3A DESICCANT
It provides the maximum level of desiccation ability in a wide temperature range. The core resistance is guaranteed with high level of vibration thanks to an anti-shock design. Suggested installation position on liquid line
- **SH48-A30 FILTER ELEMENT:**
30% 3A DESICCANT, 70% ACTIVATED ALUMINA
This solid filter element provides an excellent acid absorption together with a standard desiccation ability in a wide temperature range. The suggested installation position is on the suction line; it is suitable after compressor burnout because it removes acid, impurities and other harmful substance avoiding the damage of the new compressor.
SH48-A30 filter core is compatible with HCFC / HFC refrigerants and its design optimizes the flow passage generating low internal pressure drop. The core resistance is guaranteed with high level of vibration thanks to an anti-shock design.
- **SH48-B00 FILTER ELEMENT:**
Strainer core for filtering dirt particles. Compatible with HCFC, HFC refrigerants. Suggested installation position on suction line.

FILTER DRIERS WITH REPLACEABLE CORE



GENERAL SPECIFICATION

- Applicable for all common HCFC and HFC, HFO¹⁾ refrigerants such as: R22, R134a, R404A, R407C, R410A, R507, R407A/F, R448A/R449A, R452A, R450A/R513A, R1234ze¹⁾.
- Ambient temperature min./max.: -30°C / +55°C
- Medium temperature TS min./max.: -40°C / +70°C
- Max. operating pressure PS: from 4,5 MPa (45 bar) (see table 1)
- Installation position:
HTG with SH48-A80 or SH48-A00 in liquid line,
HTG with SH48-A30 or mechanical strainer SH48-B100 in suction line
- Certifications: UL/CSA and PED declaration

TECHNICAL PARAMETERS

Desiccant Selection Table

	Medium Type	30% 3A desiccant 70% active alumina	80% 3A desiccant 20% active alumina	100% 3A desiccant	Mechanical strainer
Core Model	-	SH48-A30	SH48-A80	SH48-A00	SH48-B00
With flange gasket suitable for Sanhua shells: Ø113,6 mm x Ø121,4 mm	-	20225000102	20225000902	20225001102	20225003302
With flange gasket suitable for Sanhua and other shells: Ø113,6 mm x Ø121,4 mm and Ø105,4 mm x Ø113,6 mm	-	20225028602	20225027702	20225028502	20225028702
Suggested Installation position	-	Suction Line	Liquid Line	Liquid Line	Suction Line
Refrigerant	HFC	Applicable	Applicable	Suggested	Suggested
	HCFC	Suggested	Suggested	Applicable	Applicable
	HC/HFO	Applicable	Applicable	Applicable	-
Oil ¹⁾	Mineral oil or AB	Suggested	Suggested	Applicable	Applicable
	Pure POE or PAG	Applicable	Applicable	Suggested	Suggested
	POE or PAG with additive	Not applicable	Not applicable	Applicable	Applicable

Note: 1) When the systems use oil with additive, it is not recommended to use a core with alumina.

Accessories and spare parts:

Universal flange gaskets set	Model	Part Number (multi package)
	HTG-000-024003	20225023802

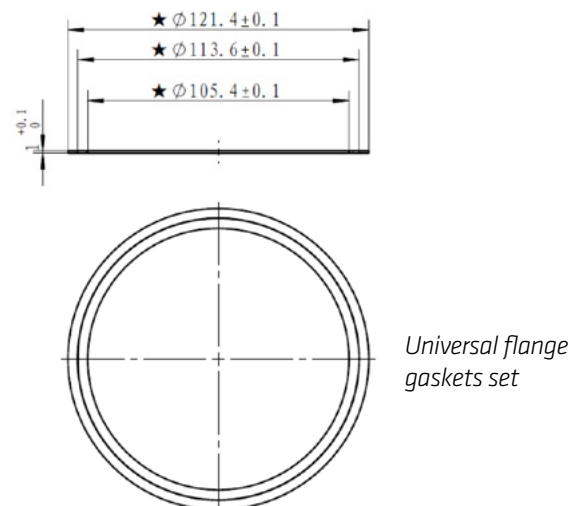
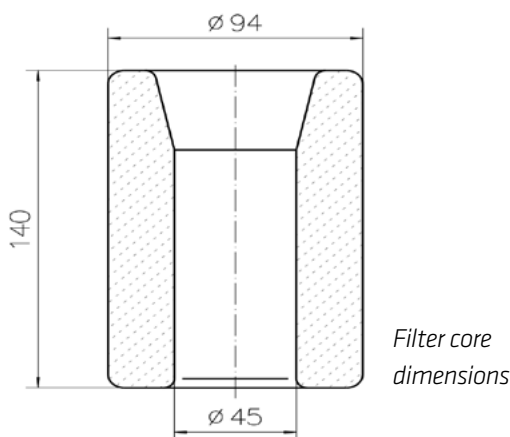

FILTER DRIERS WITH REPLACEABLE CORE



MODEL DESIGNATION EXAMPLE

Position Number						According to Model Designation Legend
1	2	3	4	5	6	
HTG	A96	28	1	901		Replaceable core filter drier
HTG	A96	28	1	901		96 inch ³ internal volume
HTG	A96	28	1	901		When Pos. 4 is "1": connection size 28mm
HTG	A96	28	1	901		Solder connection metric
HTG	A96	28	1	901		Standard product

Model Designation Legend

1	Product Code	Filter Drier Series
	HTG	Indicates replaceable core filter drier
2	Internal volume	Expressed in inch ³
	A48	48
	A96	96
	B44	144
	B92	192
3	Connection size	Pos. 4 shows "0": Solder [inch]
	05	5/8
	07	7/8
	09	1 1/8
	11	1 3/8
	13	1 5/8
	17	2 1/8
	21	2 5/8
	Connection size	Pos. 4 shows "1": Solder [mm]
	05	16 - (5/8" version can be used e.g. HTG-A48 050)
	07	22 - (7/8" version can be used e.g. HTG-A48 070)
	28	28
	11	35 - (1 3/8" version can be used e.g. HTG-A48 110)
	42	42
	17	54 - (2 1/8" version can be used e.g. HTG-A48 170)
4	Pipe Connection	Type
	0	Solder with inch connections
1 *	Solder with metric connections	
5	Version Number	Description
	901	Standard product

Note: * Solder connections which fit to metric and inch are marked with inch product codes e.g. 16, 22, 35 and 54mm

FILTER DRIERS WITH REPLACEABLE CORE



GENERAL CHARACTERISTICS OF FILTER *Table 1*

Series	Model	Part Number*	Solder Connections ODF		Number of cores	Dimensions & Weight					Design Pressure (MPa)	PED category
			[inch]	[mm]		A	B	L	G	Weight ¹⁾		
						[mm]	[mm]	[mm]	[mm]	[kg]		
HTG A48s	HTG-A48050-901	10225004502	5/8	16	1	250	164	170	116	5,1	4,5	Cat. I
	HTG-A48070-901	10225004402	7/8	22		249	163	170	116	5,1	4,5	
	HTG-A48090-901	10225004302	1 1/8	-		254	168	170	121	5,1	4,5	
	HTG-A48281-901	10225004202	-	28		254	168	170	121	5,1	4,5	
	HTG-A48110-901	10225004102	1 3/8	35		253	167	170	121	5,1	4,5	
	HTG-A48130-901	10225004002	1 5/8	-		272	186	170	141	5,1	4,5	
	HTG-A48421-901	10225003802	-	42		272	186	170	141	5,1	4,5	
	HTG-A48170-901	10225003902	2 1/8	54		275	182	170	145	5,1	4,5	
HTG A96s	HTG-A96050-901	10225003602	5/8	16	2	391	305	310	116	6,2	4,5	
	HTG-A96070-901	10225003502	7/8	22		390	304	310	116	6,2	4,5	
	HTG-A96090-901	10225003302	1 1/8	-		395	309	310	121	6,2	4,5	
	HTG-A96281-901	10225003402	-	28		395	309	310	121	6,2	4,5	
	HTG-A96110-901	10225003202	1 3/8	35		394	308	310	121	6,2	4,5	
	HTG-A96130-901	10225003102	1 5/8	-		413	327	310	141	6,2	4,5	
	HTG-A96421-901	10225003002	-	42		413	327	310	141	6,2	4,5	
	HTG-A96170-901	10225002902	2 1/8	54		416	323	310	145	6,2	4,5	
HTG B44s	HTG-B44050-901	10225002702	5/8	16	3	532	446	310	116	7,6	4,5	
	HTG-B44070-901	10225002602	7/8	22		531	445	310	116	7,6	4,5	
	HTG-B44090-901	10225002502	1 1/8	-		536	450	310	121	7,6	4,5	
	HTG-B44281-901	10225002402	-	28		536	450	310	121	7,6	4,5	
	HTG-B44110-901	10225002302	1 3/8	35		535	449	310	121	7,6	4,5	
	HTG-B44130-901	10225002202	1 5/8	-		554	468	310	141	7,6	4,5	
	HTG-B44421-901	10225002102	-	42		554	468	310	141	7,6	4,5	
	HTG-B44170-901	10225001902	2 1/8	54		557	464	310	145	7,6	4,5	
HTG B92s	HTG-B92050-901	10225001702	5/8	16	4	677	591	310	116	9,1	4,5	
	HTG-B92070-901	10225001602	7/8	22		676	590	310	116	9,1	4,5	
	HTG-B92090-901	10225001502	1 1/8	-		681	595	310	121	9,1	4,5	
	HTG-B92281-901	10225004602	-	28		681	595	310	121	9,1	4,5	
	HTG-B92110-901	10225001402	1 3/8	35		680	594	310	121	9,1	4,5	
	HTG-B92130-901	10225002002	1 5/8	-		699	613	310	141	9,1	4,5	
	HTG-B92421-901	10225001302	-	42		699	613	310	141	9,1	4,5	
	HTG-B92170-901	10225001202	2 1/8	54		702	609	310	145	9,1	4,5	
HTG-B92210-901	10225001102	2 5/8	-	704	604	310	149	9,1	4,5			

1) Weight of filter shell (must be added the filter core weight: 0.6 kg)

FILTER DRIERS WITH REPLACEABLE CORE

SELECTION TABLE - WITH CORE SH48-A00 Table 2

Model	Acid Absorption capacity (g)	Capacity [kW] ¹					Moisture Absorption [gram H ₂ O]							
		R134a	R404A	R22	R407C ²	R410A	R134a		R404A		R407C ²		R22	
			R507A				75°F	125°F	75°F	125°F	75°F	125°F	75°F	125°F
HTG-A48050-901	-	78,6	55,8	80,7	80	81,5								
HTG-A48070-901	-	125,6	89,2	128,9	128	130,3								
HTG-A48090-901	-	180,6	128,2	185,4	183,9	187,2								
HTG-A48281-901	-	180,6	128,2	185,4	183,9	187,2								
HTG-A48110-901	-	243,2	172,6	249,6	247,7	252,2	87,4	75,3	94,1	77,3	73,9	67,2	80,6	73,9
HTG-A48130-901	-	298,7	212	306,5	304,2	309,7								
HTG-A48421-901	-	298,7	212	306,5	304,2	309,7								
HTG-A48170-901	-	424,2	301,1	435,4	432	439,8								
HTG-A48210-901	-	471,2	334,4	483,6	479,9	488,6								
HTG-A96050-901	-	80,6	57,2	82,7	82	83,5								
HTG-A96070-901	-	128,8	91,4	132,2	131,2	133,5								
HTG-A96090-901	-	185,1	131,4	190	188,5	191,9								
HTG-A96281-901	-	185,1	131,4	190	188,5	191,9								
HTG-A96110-901	-	249,3	176,9	255,9	253,9	258,5	174,7	150,5	188,2	154,6	147,8	134,4	161,3	147,8
HTG-A96130-901	-	306,1	217,3	314,2	311,8	317,4								
HTG-A96421-901	-	306,1	217,3	314,2	311,8	317,4								
HTG-A96170-901	-	434,8	308,6	446,3	442,8	450,8								
HTG-A96210-901	-	483	342,8	495,7	491,9	500,8								
HTG-B44050-901	-	82,5	58,6	84,7	84	85,6								
HTG-B44070-901	-	131,9	93,6	135,4	134,3	136,8								
HTG-B44090-901	-	189,6	134,6	194,6	193,1	196,6								
HTG-B44281-901	-	189,6	134,6	194,6	193,1	196,6								
HTG-B44110-901	-	255,4	181,3	262,1	260,1	264,8	262,1	225,8	282,2	231,8	221,8	201,6	241,9	221,8
HTG-B44130-901	-	313,6	222,6	321,9	319,4	325,1								
HTG-B44421-901	-	313,6	222,6	321,9	319,4	325,1								
HTG-B44170-901	-	445,4	316,1	457,1	453,6	461,8								
HTG-B44210-901	-	494,8	351,2	507,8	503,9	513,0								
HTG-B92050-901	-	84,5	60	86,7	86	87,6								
HTG-B92070-901	-	135,1	95,9	138,6	137,5	140								
HTG-B92090-901	-	194,1	137,8	199,3	197,7	201,3								
HTG-B92281-901	-	194,1	137,8	199,3	197,7	201,3								
HTG-B92110-901	-	261,5	185,6	268,4	266,3	271,1	349,4	301,1	376,3	309,1	295,7	268,8	322,6	295,7
HTG-B92130-901	-	321,1	227,9	329,5	327	332,9								
HTG-B92421-901	-	321,1	227,9	329,5	327	332,9								
HTG-B92170-901	-	456	323,6	468	464,4	472,8								
HTG-B92210-901	-	506,6	359,5	519,9	515,9	525,2								

FILTER DRIERS WITH REPLACEABLE CORE

SELECTION TABLE - WITH CORE SH48-A80 Table 3

Model	Acid Absorption capacity (g)	Capacity [kW] ¹					Moisture Absorption [gram H ₂ O]							
		R134a	R404A	R22	R407C ²	R410A	R134a		R404A		R407C ²		R22	
			R507A				75°F	125°F	75°F	125°F	75°F	125°F	75°F	125°F
		23,9°C	51,7°C	23,9°C	51,7°C	23,9°C	51,7°C	23,9°C	51,7°C	23,9°C	51,7°C			
HTG-A48050-901	10	78,6	55,8	80,7	80	81,5	74,3	64	80	65,7	62,8	57,1	68,5	62,8
HTG-A48070-901		125,6	89,2	128,9	128	130,3								
HTG-A48090-901		180,6	128,2	185,4	183,9	187,2								
HTG-A48281-901		180,6	128,2	185,4	183,9	187,2								
HTG-A48110-901		243,2	172,6	249,6	247,7	252,2								
HTG-A48130-901		298,7	212	306,5	304,2	309,7								
HTG-A48421-901		298,7	212	306,5	304,2	309,7								
HTG-A48170-901		424,2	301,1	435,4	432	439,8								
HTG-A48210-901		471,2	334,4	483,6	479,9	488,6								
HTG-A96050-901		20	80,6	57,2	82,7	82								
HTG-A96070-901	128,8		91,4	132,2	131,2	133,5								
HTG-A96090-901	185,1		131,4	190	188,5	191,9								
HTG-A96281-901	185,1		131,4	190	188,5	191,9								
HTG-A96110-901	249,3		176,9	255,9	253,9	258,5								
HTG-A96130-901	306,1		217,3	314,2	311,8	317,4								
HTG-A96421-901	306,1		217,3	314,2	311,8	317,4								
HTG-A96170-901	434,8		308,6	446,3	442,8	450,8								
HTG-A96210-901	483		342,8	495,7	491,9	500,8								
HTG-B44050-901	30		82,5	58,6	84,7	84	85,6	222,8	191,9	239,9	197,1	188,5	171,4	205,6
HTG-B44070-901		131,9	93,6	135,4	134,3	136,8								
HTG-B44090-901		189,6	134,6	194,6	193,1	196,6								
HTG-B44281-901		189,6	134,6	194,6	193,1	196,6								
HTG-B44110-901		255,4	181,3	262,1	260,1	264,8								
HTG-B44130-901		313,6	222,6	321,9	319,4	325,1								
HTG-B44421-901		313,6	222,6	321,9	319,4	325,1								
HTG-B44170-901		445,4	316,1	457,1	453,6	461,8								
HTG-B44210-901		494,8	351,2	507,8	503,9	513,0								
HTG-B92050-901		40	84,5	60	86,7	86	87,6							
HTG-B92070-901	135,1		95,9	138,6	137,5	140								
HTG-B92090-901	194,1		137,8	199,3	197,7	201,3								
HTG-B92281-901	194,1		137,8	199,3	197,7	201,3								
HTG-B92110-901	261,5		185,6	268,4	266,3	271,1								
HTG-B92130-901	321,1		227,9	329,5	327	332,9								
HTG-B92421-901	321,1		227,9	329,5	327	332,9								
HTG-B92170-901	456		323,6	468	464,4	472,8								
HTG-B92210-901	506,6		359,5	519,9	515,9	525,2								

- Note:**
1. The data reported in the Table 2 and 3 is based on filter driers in a clean system at ideal conditions; with impurities accumulated in the filter, the capacity may decrease.
 2. R407C data based on dew point conditions
 3. Adsorption capacity of oleic acid at 0.05 TAN (Total Acid Number)

FILTER DRIERS WITH REPLACEABLE CORE



SELECTION FORMULAS

Filter driers for liquid line are manufactured in compliance with ARI Standard 710. Maximum flow rate of liquid refrigerant at a differential pressure of 0,07bar (1psi) is indicated by kW (ton) which is based on the temperature of liquid refrigerant 30°C (86°F), the evaporating temperature of -15°C (5°F) and the following mass flow:

- 0,40 kg/min/kW (3.1 lb/min/ton) R134a
- 0,53 kg/min/kW (4.1 lb/min/ton) R404A, R507A
- 0,39 kg/min/kW (3.0 lb/min/ton) R22, R407C
- 0,36 kg/min/kW (2.8 lb/min/ton) R410A

Note: Data on water absorption is based on the following EPD (method: ASHRAE Standard 63.1):

- 60ppm R22
- 50ppm R134a
- 50ppm R404A
- 50ppm R407C
- 50ppm R410A
- 50ppm R507A

SUCTION LINE FILTER-DRIERS:

Any pressure loss in the suction line also reduces system capacity significantly. Obtaining a low pressure drop is particularly important for energy savings on all the air conditioning and refrigeration systems. Therefore, suction line filter-driers should be sized generously on these systems. Sanhua suggests that the pressure drop across it should not exceed the values given in the table below (table 4: DP limits in metric units; table 5: DP limits in imperial units)

Table 4

Suction Line Filter Drier Maximum Recommended Pressure Drop (bar)					
System	Evaporator Saturated Suction Temperature ⁴⁾ (°C)	Permanent Installation		Temporary Installation	
		Refrigerant			
		R22; R404A; R407C; R410A, R507	R134a	R22; R404A; R407C; R410A, R507	R134a
Air conditioning	4	0,21	0,14	0,56	0,42
Commercial	-7	0,14	0,105	0,28	0,21
Low temperature	-29	0,07	0,035	0,14	0,07

Table 5

Suction Line Filter Drier Maximum Recommended Pressure Drop (psi)					
System	Evaporator Saturated Suction Temperature ⁵⁾ (°F)	Permanent Installation		Temporary Installation	
		Refrigerant			
		R22; R404A; R407C; R410A, R507	R134a	R22; R404A; R407C; R410A, R507	R134a
Air conditioning	40	3	2	8	6
Commercial	20	2	1,5	4	3
Low temperature	-20	1	0,5	2	1

FILTER DRIERS WITH REPLACEABLE CORE



SUCTION LINE FLOW CAPACITY WITH CORE SH48-A30 (KW)¹ Table 6

Model	Capacity (kW)											
	Evaporation temperature (°C)											
	-40	-20	4,4	-30	-20	4,4	-40	-20	4,4	-40	-20	4,4
	Pressure drop (bar)											
	0,04	0,10	0,21	0,04	0,07	0,14	0,04	0,10	0,21	0,04	0,10	0,21
	R22/R407C			R134a			R404A/R507			R410A		
HTG-A48050-901	3,0	8,5	20,0	2,9	5,1	12,4	2,3	6,7	16,6	3,0	8,5	20,0
HTG-A48070-901	5,5	15,5	36,0	5,3	9,4	22,2	4,3	12,3	29,6	5,5	15,3	36,0
HTG-A48090-901	7,4	20,5	48,5	7,1	12,6	30,0	5,7	16,3	40,0	7,4	20,5	48,5
HTG-A48281-901	7,4	20,5	48,5	7,1	12,6	30,0	5,7	16,3	40,0	7,4	20,5	48,5
HTG-A48110-901	9,5	26,0	61,0	9,1	16,0	37,5	7,3	20,7	50,0	9,5	26,0	61,0
HTG-A48130-901	9,5	26,0	61,0	9,1	16,0	37,5	7,3	20,7	50,0	9,5	26,0	61,0
HTG-A48421-901	9,5	26,0	61,0	9,1	16,0	37,5	7,3	20,7	50,0	9,5	26,0	61,0
HTG-A48170-901	9,5	26,0	61,0	9,1	16,0	37,5	7,3	20,7	50,0	9,5	26,0	61,0
HTG-A48210-901	9,5	26,0	61,0	9,1	16,0	37,5	7,3	20,7	50,0	9,5	26,0	61,0
HTG-A96050-901	3,1	8,6	20,3	3,0	5,4	12,7	2,4	7,0	17,1	3,1	8,7	20,5
HTG-A96070-901	5,5	15,4	36,2	5,3	9,4	22,4	4,3	12,3	29,8	5,5	15,4	36,2
HTG-A96090-901	8,3	23,4	55,4	8,0	14,3	34,1	6,5	18,7	46,0	8,3	23,4	56,0
HTG-A96281-901	8,3	23,4	55,4	8,0	14,3	34,1	6,5	18,7	46,0	8,3	23,4	56,0
HTG-A96110-901	11,3	32,0	76,0	10,8	19,4	46,5	8,8	25,5	63,0	11,3	32,0	76,0
HTG-A96130-901	13,5	38,0	91,0	13,0	23,1	55,6	10,5	30,4	75,0	13,4	38,0	91,0
HTG-A96421-901	13,5	38,0	91,0	13,0	23,1	55,6	10,5	30,4	75,0	13,4	38,0	91,0
HTG-A96170-901	13,5	38,0	91,0	13,0	23,1	55,6	10,5	30,4	75,0	13,4	38,0	91,0
HTG-A96210-901	13,5	38,0	91,0	13,0	23,1	55,6	10,5	30,4	75,0	13,4	38,0	91,0
HTG-B44050-901	3,3	9,5	21,7	3,2	5,7	13,3	2,6	7,3	16,5	3,3	9,5	21,7
HTG-B44070-901	6,3	18,0	41,0	6,0	10,6	25,1	4,8	13,8	34,0	6,3	18,0	41,0
HTG-B44090-901	8,4	24,0	55,0	8,0	14,3	34,0	6,5	18,5	46,0	8,4	24,0	55,0
HTG-B44281-901	8,4	24,0	55,0	8,0	14,3	34,0	6,5	18,5	46,0	8,4	24,0	55,0
HTG-B44110-901	12,5	36,5	89,0	12,1	22,0	54,0	9,8	29,2	73,0	12,5	36,5	89,0
HTG-B44130-901	12,5	36,5	89,0	12,1	22,0	54,0	9,8	29,2	73,0	12,5	36,5	89,0
HTG-B44421-901	12,5	36,5	89,0	12,1	22,0	54,0	9,8	29,2	73,0	12,5	36,5	89,0
HTG-B44170-901	12,5	36,5	89,0	12,1	22,0	54,0	9,8	29,2	73,0	12,5	36,5	89,0
HTG-B44210-901	12,5	36,5	89,0	12,1	22,0	54,0	9,8	29,2	73,0	12,5	36,5	89,0
HTG-B92050-901	4,0	10,9	25,9	3,8	6,7	16,0	3,0	8,7	21,6	4,0	10,9	25,9
HTG-B92070-901	7,5	20,5	48,8	7,2	12,7	30,0	5,8	16,5	40,6	7,5	20,5	48,8
HTG-B92090-901	10,1	27,5	66,0	9,7	17,1	40,0	7,8	22,1	54,3	10,1	27,5	66,0
HTG-B92281-901	10,1	27,5	66,0	9,7	17,1	40,0	7,8	22,1	54,3	10,1	27,5	66,0
HTG-B92110-901	14,1	39,7	95,0	13,6	24,2	58,1	11,0	31,9	78,1	14,1	39,7	95,0
HTG-B92130-901	17,1	49,0	118,0	16,5	30,0	72,0	13,4	39,0	97,0	17,1	49,0	118,0
HTG-B92421-901	17,1	49,0	118,0	16,5	30,0	72,0	13,4	39,0	97,0	17,1	49,0	118,0
HTG-B92170-901	17,1	49,0	118,0	16,5	30,0	72,0	13,4	39,0	97,0	17,1	49,0	118,0
HTG-B92210-901	17,1	49,0	118,0	16,5	30,0	72,0	13,4	39,0	97,0	17,1	49,0	118,0

FILTER DRIERS WITH REPLACEABLE CORE



The capacities listed in the table 6 are rated at the maximum recommended pressure drop for permanent installation. Suction line Filter-Driers guarantees an acid removal and a drying capacity described in table 7:

Table 7

Drying capacity: SH48-A30 ¹⁾					
Filter Type		HTG-A48	HTG-A96	HTG-B44	HTG-B92
Number of cores		1	2	3	4
Acid Adsorption capacity (g) ³⁾		28,0	56,0	84,0	112,0
Refrigerant	Evaporating Temp. (°C) ⁴⁾	Moisture Absorption [gram H2O]			
R22/ R407C ²⁾	-40,0	26,0	52,0	78,0	104,0
	-20,0	18,0	36,3	54,0	72,0
	4,4	11,0	22,0	32,0	43,0
R134a	-30,0	43,0	86,0	129,0	172,0
	-20,0	36,0	72,0	108,0	144,0
	4,4	25,0	50,0	75,0	100,0
R404A / R507	-40,0	45,0	90,0	135,0	180,0
	-20,0	28,0	56,0	84,0	112,0
	4,4	18,0	36,0	54,0	72,0
R410A	-40,0	40,0	80,0	120,0	160,0
	-20,0	33,0	66,0	99,0	132,0
	4,4	24,0	48,0	72,0	96,0

Drying capacity is expressed during drying in:

- R22: EPD = 10 ppm W, corresponding dew point temperature is -50°C
- R134a: EPD = 50 ppm W, corresponding dew point temperature is -37°C
- R404A: EPD = 10 ppm W, corresponding dew point temperature is -40°C
- R407C: EPD = 10 ppm W, corresponding dew point temperature is -40°C

- Note:**
1. The data reported in the Table 2, 3, 6 and 7 are based on filter driers in a clean system at ideal conditions; with impurities accumulated in the filter, the capacity may decrease.
 2. R407C data based on dew point conditions
 3. Adsorption capacity of oleic acid at 0.05 TAN (Total Acid Number)
 4. Standard Evaporating Temperature defined by ANSI.AHRI Standard 731 (SI)-2013
 5. Standard Evaporating Temperature defined by ANSI.AHRI Standard 730 (I-P)-2013

