

DPF-R SERIES

CO₂ ELECTRONIC EXPANSION VALVES

R series electronic expansion valves are used in air conditioning and refrigeration systems with variable refrigerant flow to realize automatic adjustment of refrigerant flow rate and make the system work under the best working condition for the purpose of fast cooling, precise temperature control and power saving. These valves are unidirectional and can also be used for other controls on request.



FEATURES

- SMALLER INSTALLATION SPACE: LOW HEIGHT, SMALL VOLUME AND LIGHT WEIGHT
- SNAP-ON COIL FOR EASIER INSTALLATION
- DESIGN FOR R744 APPLICATION WITH 140BAR

GENERAL SPECIFICATIONS

- Applicable for R744 (CO₂) specifically
For other refrigerants, please contact your local support
- Unidirectional operation
- Design pressure PS: 140bar
- Medium temperature TS min./max.: -40°C / +80°C (duty cycle rate below 40%)
- Ambient temperature min./max.: -40°C / +60°C (duty cycle rate below 40%)
- 500 steps (full stroke)
- Relative humidity: 0 to 95%RH
- Flow direction: from horizontal tube to vertical tube
- Installation mode: coil upwards, central axis of valve rotor +/- 15° vertical to horizontal
- Certification: declaration of PED or LVD

DPF-R SERIES

CO₂ ELECTRONIC EXPANSION VALVES



ELECTRICAL PARAMETERS

Coil	PQ-M10	PQ-M08
Rated voltage	12V DC(± 10%), rectangular wave	
Excitation mode	1 - 2 phase excitation, unipolar actuation	
Excitation rate	30 - 90pps	30 - 40pps
Full stroke time	13s @40pps, 6s @90pps0	
Coil current	260mA/phase (20°C)	375 mA/phase (20°C)
Coil resistance	46 ± 3.7Ω/phase (20°C)	32 ± 3.2Ω/phase (20°C)
Insulation class of coil	E	

TECHNICAL CHARACTERISTICS

Valve Model	Seat Φ	Max. Cooling Capacity 0°C/-20°C/6K/2K ¹	Max. Working Pressure	Kv	MOPD
	[mm]	[kW]	[bar]	[m ³ /h]	[bar]
DPF(R04) 1.0D	1,0	7,1	140	0.045	100
DPF(R04) 1.5D	1,5	14,9	140	0.115	100
DPF(R05) 2.4D	2.4	35,6	140	0.23	100

1: Condensing temp./Evaporating temp./Superheating

Valve Model	U11 Code	Coil Model	Cable length	U11 Code
DPF(R04) 1.0D-04	10130414402	PQ-M10012-001059	0.7m	10810138802
		PQ-M10012-001002	2m	10810130702
DPF(R04) 1.5D-07	10130394102	PQ-M10012-001268	5m	10810160602
		PQ-M08012-001301	0.7m	10810171402
DPF(R05) 2.4D-03	10130425302	PQ-M08012-001304	2m	10810211702
		On request	5m	On request

DPF-R SERIES

CO2 ELECTRONIC EXPANSION VALVES



CAPACITY TABLES

(R744: SUPERHEATING = 6K)

Capacity(kW) for R04-1.0		Inlet Temp. at EEV(°C)												
		-30	-25	-20	-15	-10	-5	0	5	10	15	20	25	30
Te(°C)	-40	5,0	6,1	6,9	7,6	8,2	8,6	8,9	9,1	9,2	9,1	8,9	8,5	7,8
	-35	3,7	5,1	6,2	7,0	7,7	8,2	8,6	8,9	9,0	9,0	8,8	8,4	7,8
	-30		3,8	5,2	6,3	7,1	7,7	8,2	8,5	8,7	8,7	8,6	8,3	7,6
	-25			3,8	5,3	6,3	7,1	7,7	8,1	8,4	8,5	8,4	8,1	7,5
	-20				3,8	5,3	6,3	7,1	7,6	7,9	8,1	8,1	7,8	7,3
	-15					3,9	5,3	6,3	7,0	7,4	7,7	7,7	7,5	7,1
	-10						3,8	5,2	6,2	6,8	7,1	7,3	7,2	6,8
	-5							3,8	5,1	6,0	6,5	6,8	6,8	6,5
	0								3,7	5,0	5,7	6,1	6,3	6,1
	5									3,6	4,7	5,4	5,6	5,6
	10										3,4	4,4	4,9	5,0
	15											3,1	4,0	4,3

Capacity(kW) for R04-1.5		Inlet Temp. at EEV(°C)												
		-30	-25	-20	-15	-10	-5	0	5	10	15	20	25	30
Te(°C)	-40	10,6	12,8	14,6	16,1	17,2	18,2	18,8	19,3	19,4	19,3	18,8	17,9	16,5
	-35	7,8	10,8	13,1	14,8	16,2	17,3	18,2	18,7	19,0	18,9	18,6	17,7	16,4
	-30		7,9	11,0	13,3	15,0	16,3	17,3	18,0	18,4	18,5	18,2	17,4	16,1
	-25			8,0	11,2	13,4	15,0	16,2	17,1	17,7	17,9	17,7	17,0	15,8
	-20				8,1	11,2	13,3	14,9	16,0	16,8	17,1	17,1	16,5	15,5
	-15					8,1	11,2	13,2	14,7	15,7	16,2	16,3	15,9	15,0
	-10						8,1	11,0	13,0	14,3	15,1	15,4	15,2	14,4
	-5							8,0	10,8	12,6	13,7	14,3	14,3	13,6
	0								7,8	10,5	12,1	13,0	13,2	12,8
	5									7,5	10,0	11,4	11,9	11,8
	10										7,1	9,3	10,4	10,5
	15											6,6	8,5	9,1

Capacity(kW) for R05-2.4		Inlet Temp. at EEV(°C)												
		-30	-25	-20	-15	-10	-5	0	5	10	15	20	25	30
Te(°C)	-40	25,3	30,6	34,9	38,4	41,2	43,4	45,0	46,0	46,4	46,1	45,0	42,8	39,4
	-35	18,5	25,9	31,2	35,4	38,8	41,4	43,4	44,7	45,3	45,2	44,3	42,3	39,0
	-30		18,9	26,3	31,6	35,7	38,9	41,3	43,0	43,9	44,1	43,4	41,6	38,5
	-25			19,2	26,3	31,9	35,8	38,8	40,9	42,2	42,6	42,2	40,6	37,8
	-20				19,4	26,7	31,8	35,6	38,3	40,0	40,8	40,7	39,5	36,9
	-15					19,4	26,7	31,6	35,0	37,4	38,7	38,9	38,0	35,7
	-10						19,3	26,4	31,0	34,1	36,0	36,7	36,2	34,3
	-5							19,0	25,8	30,0	32,8	34,1	34,1	32,5
	0								18,6	25,0	28,8	30,9	31,5	30,5
	5									17,9	23,8	27,1	28,5	28,0
	10										17,0	22,3	24,8	25,2
	15											15,8	20,2	21,7

DPF-R SERIES CO2 ELECTRONIC EXPANSION VALVES



FLOW CHARACTERISTIC

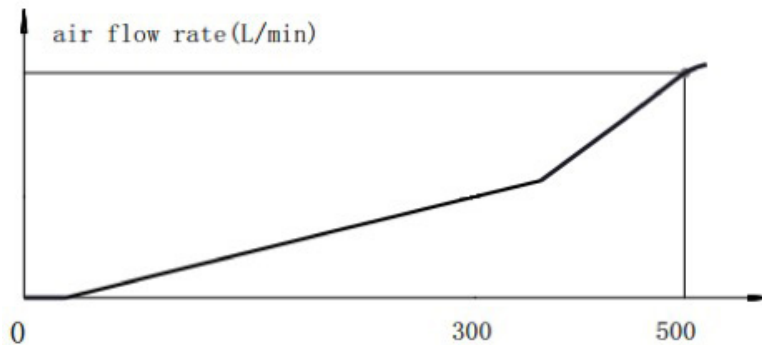

DIMENSIONS

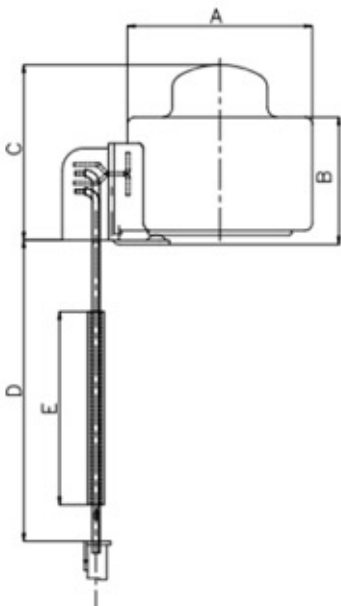

Coil model	Dimensions [mm]					Coil Weight [kg]
	A	B	C	D	E	
PQ-M10012-001059	38.5	26.4	35.8	700	600	0,12
PQ-M10012-001002	38.5	26.4	35.8	2000	1800	
PQ-M10012-001268	38.5	26.4	35.8	5000	4500	
PQ-M08012-001301	46	30.1	48.1	700	600	0,15
PQ-M08012-001304	46	30.1	48.1	2000	1800	0,15

Valve model	Dimensions [mm]					Valve Weight [kg]
	F	G	H	M	N	
DPF(R04) 1.0D-04	93.5	50	47	6.35	17.35	0,04
DPF(R04) 1.5D-07	93.5	50	47	6.35	17.35	
DPF(R05) 2.4D-03	117	58	54	7.94	21.75	0,11
DPF(R05) 2.4D-05	119	60	60	6.35	21.75	

